



PRODUCT BROCHURE

May • 2026



DEFINED BY
CONNECTION.
Dedicated to support.

Introduction	4
The Commtel Difference	6
Resource HUB	8
Features	10
Dimensions	14
IP Intercoms	16
NX1	20
NX250	21
4G Intercoms	22
SOLO	22
SOLO+	23
DUO+	24
TRIO+	25
JUNIOR	26
VARIO	27
MILLENNIUM	28
VISION	29
SENIOR	30
HUBS & SATELLITES	32
Access Control	34
TELPAD II	34
COMMAND UNIT	35
SIM Cards	36
Product Matrix	38
Custom Solutions	42
Apps	44
Our History	46

INTRODUCTION

For over 30 years, we've been building intercoms with a steadfast focus on what matters most: **You, our customer.**

We've continually grown by staying close to what the industry's needs are – providing reliable, high-quality products that installers and end-users can count on. Our products are designed and built right here in the UK, a testament to our commitment to solutions of enduring quality.

We see our role as more than a supplier.

We are a dedicated partner, wholly invested in your success. That's why our systems are designed for straightforward installation and operation, backed by the comprehensive support you need, from your initial inquiry to your project completion.

With Commtel, you gain a partner you can depend on. We are defined by connection, and dedicated to support.

So, why Commtel?

We understand the hard work and expertise that goes into every installation. The final step, the communication at the entrance.

Our purpose is to ensure that this is the most seamless and reliable part of the job. Our approach is to be **the trusted partner** who makes that final stage effortless, allowing installers to deliver a flawless finish every time.



THE COMMTEL DIFFERENCE

What truly sets us apart isn't just what we build, but how we build it, and the relationships we build along the way.

Our unique value is grounded in three core pillars that directly benefit our customers and define our commitment to your success:

Human-Centric Approach:

We firmly believe in the power of genuine connections, and we prioritise building and maintaining those strong relationships with our installers and partners.

By fostering open communication and providing personalised support, we aim to create a collaborative environment focused on joint success.

Future-Forward Expertise:

We understand the fundamentals of the market and are definitively positioned to maximise on future technologies, evolving with the market to provide solutions for our customers.

Unwavering Commitment:

We are driven to excel in every aspect of our business. From the quality of our products to the integrity of our practices, we hold ourselves to the highest standards.

This commitment ensures our customers can rely on us to deliver reliable, durable, and ethically sound solutions that last.

RESOURCE HUB

As part of our renewed focus on support and simplicity, we've created a dedicated Resource Hub; a single, central space designed to make your working life easier.

We know that reliable information is as vital as reliable products. From installation to everyday use, having the right documentation at hand ensures every Commtel system performs exactly as intended. The Resource Hub brings all our product knowledge together in one accessible place, giving you confidence that you're always working from the most accurate, up-to-date information.

You'll now have direct access to:

- **Installation Guides:** Step-by-step setup for each product (Requires you to be logged in on the website)
- **Specification Documents:** Detailed technical information
- **User Guides:** Clear instructions for day-to-day operation
- **App Guides:** Practical support for connected solutions

The Resource Hub is more than a library; it's part of how we're evolving as a company. It represents our promise to make quality not just something you can see and feel, but something you can depend on at every stage of your experience with Commtel.

Explore our Resource Hub



Whether you're specifying, installing, or maintaining a Commtel system, the Resource Hub keeps everything aligned to ensure that everyone involved can work from the same trusted source.

Click the icon on the right or visit: commtel.io/support/resource-hub



FEATURES

Our entry solutions are built to give you control over how access is managed across a site, from how entry is granted, to how systems behave, and how they are maintained over time.

Each feature is designed to support real-world use, giving installers the flexibility to configure systems around the needs of each site, while allowing end users to interact with access control in a way that fits their day-to-day routines. It's about creating systems that work as expected once installed, without adding unnecessary complexity.

For a comprehensive overview of our full product range, and to see how these features apply across each system, please refer to the full product matrix on pages 38 – 41.

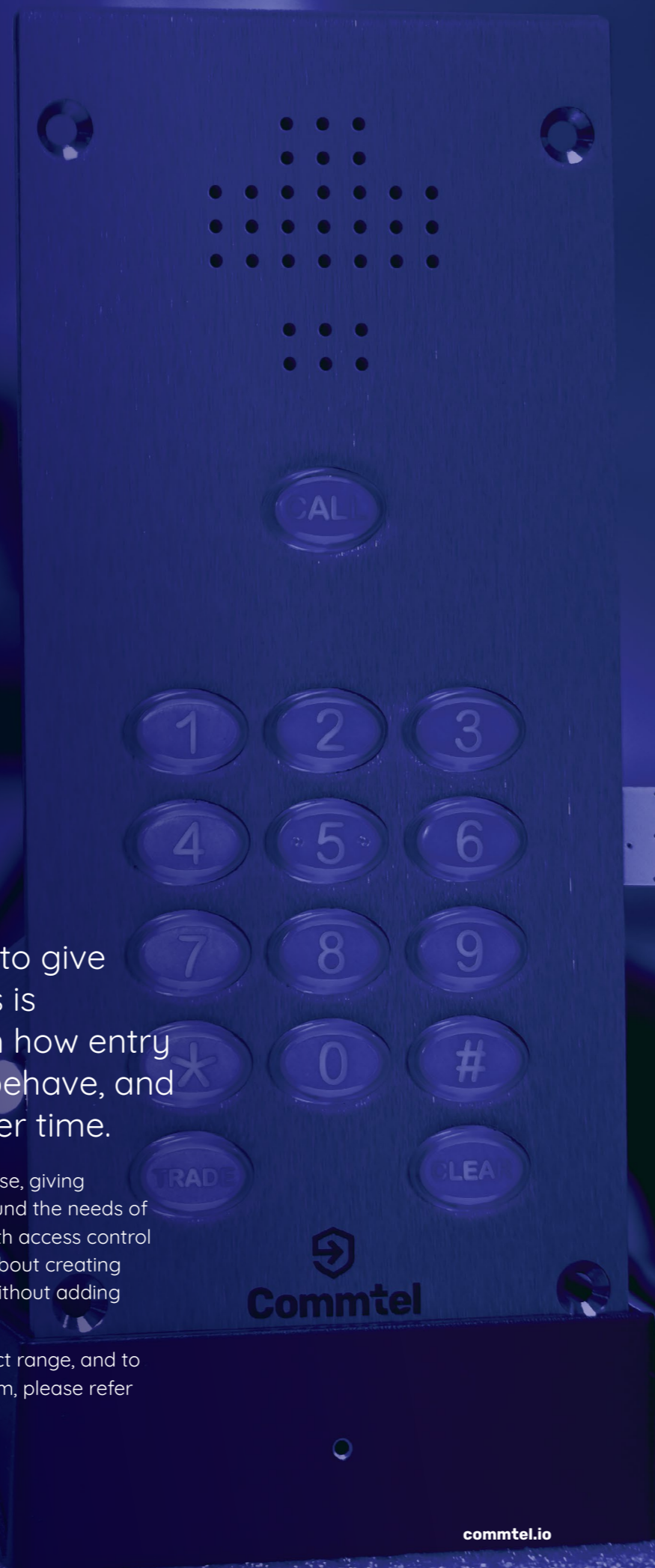

Access & Control

Managing entry on site needs to be simple, reliable, and adaptable to different users. From permanent residents to short-term visitors, systems must support multiple ways of granting access while remaining easy to manage and secure in day-to-day use.



PIN Code Entry

Where a keypad is present, Commtel systems can store up to 400 entry codes, *including temporary PINs for short-term access such as contractors, deliveries, or visitors.*

Commonly used to manage short-term access without issuing keys or fobs, particularly on sites with frequent visitors or multiple users.

- Supports temporary and permanent access
- Can be assigned to specific users or roles
- Works alongside time-based access settings.



SMS Commands

Control the system remotely via text message. Commands can open entrances, request status, reset outputs, acknowledge alerts, and more. Useful for remote sites or where data access is limited.

- Trigger access without an app
- Request system status remotely
- Reset or control outputs from anywhere.

Please note: SMS commands are not applicable to the NX range.



Relays & Auxiliary Inputs

Commtel systems include configurable relay outputs, allowing installers to connect and control gates, barriers, doors, turnstiles, and other powered entrances from a single unit.

Enables a single system to sit at the centre of site entry, connecting multiple access points and external triggers into one system.

- Connect multiple entry points
- Integrate with external triggers (exit buttons, loops)
- Centralise control through one unit.



System Customisation

Give users control over how their system looks and sounds, using the settings menu in the Commtel CONFIG app:

- **Keypad Brightness** – Adjust brightness via a simple slider.
- **Panel Volume** – Change audio level using the volume slider.
- **Keypad Colour** – Choose a colour from the drop-down menu (availability varies by model).

Automation & Integration

Once installed, Commtel systems are designed to do more than respond to input. They operate in line with how a site runs. By aligning behaviour to schedules, usage patterns, and connected equipment, access can be managed consistently without relying on manual intervention.

Flexible Time Management

Maximise control with Time Profiles:

- **Timed Relay Control** – Operate relays automatically at set times.
- **Timed Access Allocation** – Allow temporary or scheduled access windows.
- **Timed Auxiliary Inputs** – Trigger external devices or automation based on time settings.
- **Timed Call Diverts** – Redirect calls to different numbers based on the schedule.
- **Timed Latch** – Keep a door or gate open for a predefined period before automatically securing again – ideal for schools, deliveries, visitor windows, and timed site access.

Designed for sites where access changes throughout the day, reducing the need for manual control and ensuring entry behaves as expected.

Auxiliary Inputs (Integration)

Auxiliary inputs can trigger actions or alerts within the system, providing greater flexibility when integrating the system with wider site access control.

Supports integration with wider site infrastructure, allowing the system to respond to real-world triggers rather than isolated inputs.



Commtel CONFIG App

Set up and manage Commtel systems with the CONFIG app.

Used by installers to configure, adjust, and maintain systems remotely, without returning to site.

Available on both Android and iOS.

Management, Support & Insight

Ongoing performance depends on visibility, control, and the ability to make changes without disruption. From monitoring activity to adjusting system settings, having the right tools in place ensures systems remain effective, supported, and easy to manage over time.

Notifications

Commtel products can be programmed to send text alerts, helping you stay informed about activity on site, from unauthorised access attempts to important events.

- **Auxiliary input alerts** – notifications triggered by connected external equipment.
- **Event alerts** – receive a notification when specific entry codes are used or when access is granted from a particular authorised number.
- **Service reminders** – automated messages to let customers know when their service is due.

Keeps users aware of activity as it happens, without needing to check the system directly.

Please note: notifications for the NX range are delivered through the app.

Security & Diagnostics

The Activity Log provides an audit trail of system events, helping identify issues and track access. It can be downloaded via our Cirrus cloud platform or upon request from our support team.

Provides visibility when something isn't working as expected, helping reduce time spent diagnosing issues.

Please note: activity logs for NX intercoms can be viewed in the Commtel NEXUS app.

Remote Setup & Ongoing Support

Systems can be configured remotely through the Commtel CONFIG App, allowing installers to adjust settings and manage access securely without needing to return to site.

Reduces repeat site visits and allows changes to be made quickly when requirements evolve.

We can support installers by pre-programming systems prior to dispatch and assisting with commissioning remotely, helping ensure installs are set up smoothly and ready to go.

DIMENSIONS

Commtel's commitment to providing tailored solutions extends beyond functionality to encompass design and integration.

Standard Back Boxes

We understand that the aesthetic appeal and physical fit of our products are crucial. Our products are designed for ease of installation under a range of back box options to suit various solutions:

- **Small Die-Cast Back Box:** Designed for our access control solution, TELPAD II, this back box provides a compact and discreet mounting solution.
- **Our standard Die-Cast Back Box:** Balancing a sleek profile with sufficient space for connections and mounting. This back box is used across our best selling products like the SOLO+ and JUNIOR.
- **The Large Die-Cast Back Box:** Our larger intercoms, such as the VARIO, MILLENNIUM and SENIOR feature an expanded back box designed to house additional buttons and an OLED display.

Stainless Steel Back Box Options

In addition to our standard die-cast range, Commtel intercoms are also available with stainless steel back box options across all three sizes. These include both surface-mounted and flush-mounted variants, providing greater flexibility where installation finish or environmental conditions require a more robust or integrated solution.

Stainless steel options are well suited to sites where durability, weather resistance, or a refined architectural finish are a priority.

Customisation

For projects with unique aesthetic or installation demands, we offer extensive customisation options. From non-standard dimensions to bespoke finishes, we can work with you to create a solution that perfectly complements your project.

Contact our sales team to discuss your specific requirements and explore the possibilities for tailored solutions, call +44(0)1306 710120 - (Option 2) or email sales@commtel.io

Small cast
(40mm overall depth)

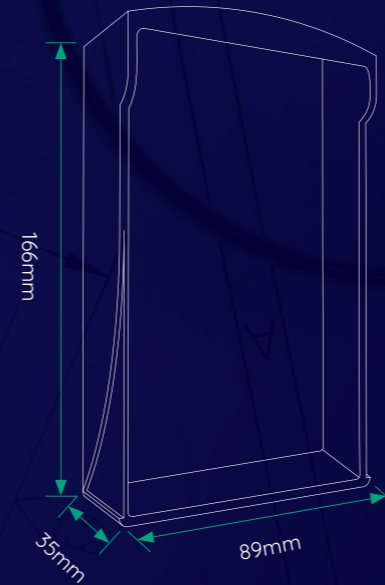

Standard cast
(40mm overall depth)

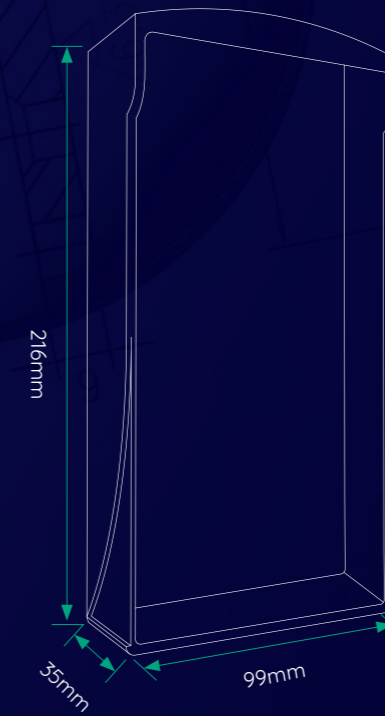

Large cast
(40mm overall depth)

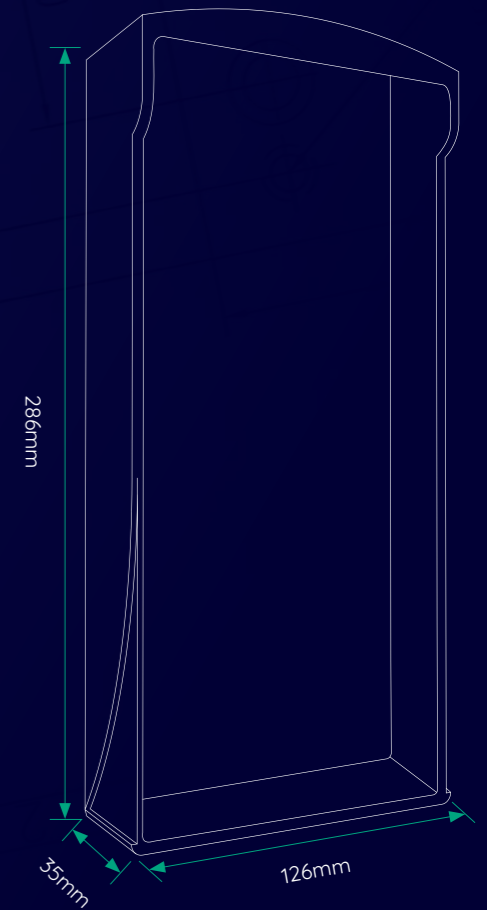

TELPAD II

Page 34



SOLO+

Page 23



MILLENNIUM

Page 28

Commtel's IP intercoms are designed to deliver reliable, connected entry across a wide range of sites.

Built on our experience in telecommunications, the NX1 and NX250 provide scalable, adaptable solutions that support modern access requirements without adding unnecessary complexity.

Why IP Intercoms?

IP intercoms use network connectivity to provide video, remote management, and scalable system control.

For installers, this means a system that integrates into existing infrastructure while remaining easy to configure, expand, and support over time.

- Network-based connectivity
- Remote system management
- Scalable across site sizes
- Supports video and app-based control.

For more information on how Commtel IP intercoms can support your next project, contact the team on +44 (0)1306 710120 or email sales@commtel.io

NX1 & NX250

The NX1 offers a compact solution suited to smaller or single-entry sites.

The NX250 is designed for larger or multi-user environments, supporting up to 250 properties and 1,000 users, with a clear OLED directory for easy navigation.

Both systems support 4G and Ethernet connectivity as standard, providing flexibility across different installation scenarios.

System Setup & User Control

System setup and configuration is carried out using the Commtel CONFIG app, allowing installers to programme and manage systems remotely.

The Commtel NEXUS app provides end-user control, enabling users to receive calls, view visitors, and manage access directly from their device.



NX250

NX1

Experience the difference that comes from a genuine partnership.

www.commtel.io

SMART ACCESS. WHEREVER YOU ARE.

Through the Commtel NEXUS app, NX intercoms connect with familiar technology like Apple CarPlay, Siri, Google Home, and Alexa, allowing access to be managed away from the entrance using devices people already rely on day to day.

Android Auto & Apple CarPlay

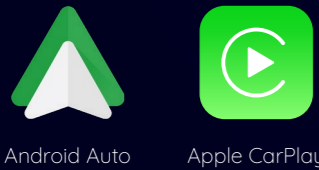

Open the gate without leaving the driver's seat.

When a user's phone is connected to Apple CarPlay or Android Auto, the NEXUS app becomes available directly on the vehicle's display. That means the entrance can be opened from the dashboard screen while arriving at the property with no need to reach for a phone or make a call.

For sites where vehicles are constantly arriving and leaving, it's a simple way to make entry faster and more convenient.

Key benefits

- Access the Commtel NEXUS app through the vehicle display.
- Trigger gate or barrier relays from the dashboard.
- Ideal for residential driveways and vehicle entrances.
- Designed to work seamlessly with the NX IP intercom.

Voice Assistants



Works with Google Home, Siri and Alexa, allowing entry to be controlled through familiar voice assistants.

NX intercom systems integrate with the NEXUS app to enable voice-triggered access. Commands issued through a connected device are processed securely, allowing authorised users to open an entrance without needing to navigate the app or place a call.

This creates a more natural way to manage entry, whether granting access from inside the property, responding from the office, or arriving at the entrance. The interaction is simple, immediate and fits into how users already interact with their devices.

Typical uses

- Granting access without reaching for a phone.
- Hands-free control from inside a property.
- Simple interaction with a familiar device.
- Built Around the Commtel NEXUS App.

Commtel NEXUS App



Commtel CONFIG App

A purpose-built app for installers to set up Commtel systems.

System configuration is handled here where the installer defines call routing, access permissions and system behaviour, preparing the system for day-to-day use.



The NEXUS app acts as the user interface for NX systems, handling calls, notifications and access requests during day-to-day use.

Connecting the intercom to the user's device, enabling new ways to interact with the system, from in-app control to voice commands and in-vehicle access.

NX1



Faceplate Finish



BLACK

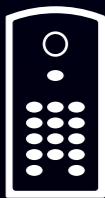

Click the icon to learn more about the NX1

The NX1 intercom from Commtel, marks a major step forward in delivering modern and advanced technology.

The NX1 comes with both Ethernet and 4G connectivity as standard, ensuring flexibility on any installation. With remote management through the Commtel NEXUS app, the NX1 provides a seamless and reliable experience for both installers and end-users.

Advanced Secure Entry

The NX1 ensures safe, controlled entry for homeowners, businesses, and site managers:

- **Dual Connectivity:** Choose between Ethernet or 4G.
- **Temporary Entry Codes:** Generate time-limited or use-limited codes directly from your phone.
- **Worldwide Timeclock:** Seamlessly schedule entry permissions, keypad settings, and relay functions.
- **Relay Action Snapshots:** Receive instant photo verification when an entry code or trade button is used.
- **Comprehensive Activity Log:** Track all panel events, from calls to relay activations.

Flexible Configuration & Smart Management

Engineered for efficiency, the NX1 simplifies installation and empowers users with advanced control:

- **App-Driven Setup:** Installers can configure the panel in minutes using the Commtel CONFIG app.
- **Ongoing User Control:** End-users enjoy complete management of entry settings and notifications via the Commtel NEXUS app.
- **Push Notifications:** Get real-time alerts for key events, from callpoint presses to triggered inputs.

For a comprehensive list of features, please refer to our product matrix on pages 38 – 41.

Product Specifications

- **Dimensions:** H 216 x W 99 x D 35 mm
- **Faceplate:** Stainless steel with powder-coated black finish
- **Surface Back Boxes:** Moulded aluminium with powder-coated black finish



Commtel NEXUS App

Allows users to see and speak to their visitors, as well as configuring their NX1 and NX250.

NX250



Faceplate Finish



BLACK

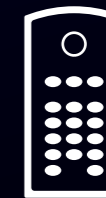

Click the icon to learn more about the NX250

The NX250 is Commtel's multi-user IP video intercom, purpose-built for larger residential and commercial sites.

Supporting up to 250 properties and unlimited users, it delivers the same powerful features as the NX1, with the addition of an OLED directory for intuitive visitor navigation. The NX250 provides a robust and scalable solution for modern secure entry.

Advanced Secure Entry

The NX250 combines capacity and convenience with a comprehensive suite of intelligent features:

- **Dual Connectivity:** Choose between Ethernet or 4G for flexible installation and reliable performance.
- **Temporary Entry Codes:** Generate time-limited or use-limited codes directly from your phone.
- **Worldwide Timeclock:** Seamlessly schedule entry permissions, keypad settings, and relay functions.
- **Relay Action Snapshots:** Receive instant photo verification when an entry code or trade button is used.
- **Comprehensive Activity Log:** Track all panel events, from calls to relay activations.

Flexible Configuration & Smart Management

Designed to handle high traffic and multiple users, the NX250 supports installers and residents alike:

- **App-Driven Setup:** Installers can configure the panel in minutes using the Commtel CONFIG app.
- **Ongoing User Control:** End-users enjoy complete management of entry settings and notifications via the Commtel NEXUS app.
- **Push Notifications:** Get real-time alerts for key events, from callpoint presses to triggered inputs.
- **OLED Directory:** Visitors can easily search and call the right property through the integrated display.

For a comprehensive list of features, please refer to our product matrix on pages 38 – 41.

Product Specifications

- **Dimensions:** H 286 x W 126 x D 35 mm
- **Faceplate:** Stainless steel with powder-coated black finish
- **Surface Back Boxes:** Moulded aluminium with powder-coated black finish

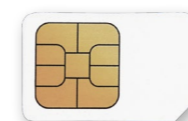

Choose the right SIM.

Discover the Commtel SIM tariff options, detailed on page 36.

SOLO

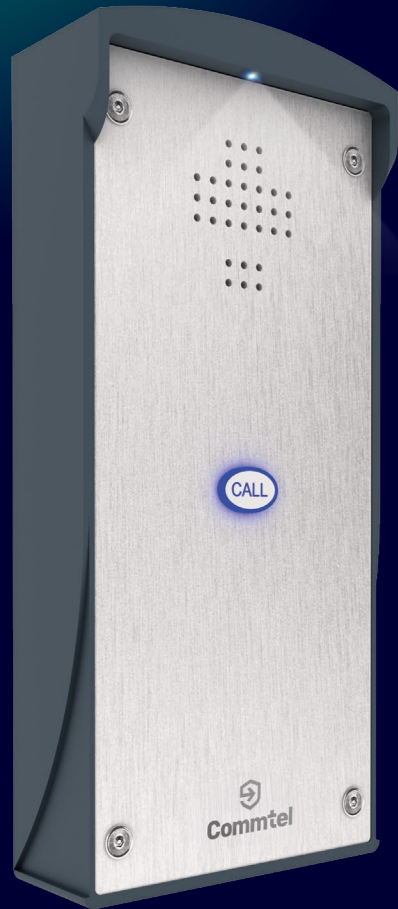

Faceplate Finish Options

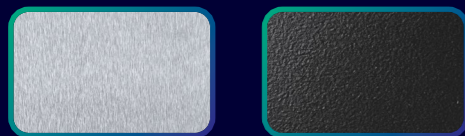

STAINLESS STEEL ANTHRACITE



Click the icon to learn more about the SOLO

Our SOLO intercom delivers reliable access control through essential functionality.

Designed for straightforward communication, the SOLO provides a practical solution for secure entry.

Intelligent Call Management

The SOLO intercom features a built-in time clock that enables intelligent call handling.

- **Flexible Call Diversion:** Easily divert calls to alternative numbers during specified periods, ensuring calls are always answered efficiently.
- **Precise Call Disabling:** If required, the call button can be disabled during designated times, providing enhanced control over when calls are received.

Enhanced Secure entry

The SOLO intercom offers tailored access management and robust security features.

- **Tailored Access Restriction:** Precisely control access by utilising time-restricted authorised dial-to-open numbers, granting entry only to permitted individuals at specified times.
- **Detailed Access Monitoring:** Enhance security and gain peace of mind with the downloadable activity log, which provides a record of entry events.
- **Automated Entry Operation:** The authorised dial-to-open function can be used to automate entry equipment such as gates, barriers, and bollards, allowing for convenient and efficient access during specified hours.
- **Adaptable Keypad Illumination:** Customise the keypad lighting to suit its surroundings by adjusting the brightness or colour as required.

For a comprehensive list of features, please refer to our product matrix on pages 38 – 41.

Product Specifications

- **Dimensions:** H 216 x W 99 x D 35 mm
- **Faceplates:** All faceplates are stainless steel with an option for powder-coated anthracite grey (RAL 7016).
- **Surface Back Box Options:**
 - Moulded aluminium, powder-coated anthracite grey (RAL 7016).
 - 316 Marine grade stainless steel
- **Flush Back Boxes:** Flush back boxes are 316 Marine grade stainless steel.

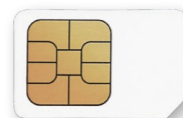

Choose the right SIM.

Discover the Commtel SIM tariff options, detailed on page 36.

Our best-selling SOLO+ intercom system is a focused solution with a built-in keypad.

This single call button intercom solution, like all Commtel intercoms, delivers a wealth of practical benefits and powerful features.

Advanced Secure Entry

The SOLO+'s integrated time clock empowers homeowners and site managers with sophisticated access management.

- **Precise Access Restriction:** Enhance security and enjoy peace of mind by precisely controlling access through time-restricted entry codes and authorised dial-to-open numbers.
- **Automated Entry Operation:** Seamlessly automate the operation of entry equipment such as gates, barriers, and bollards, enabling convenient and efficient access management during specified hours.
- **Intelligent Call Management:** Ensure privacy and optimise call handling by diverting or disabling the call button during designated times.
- **Customisable Keypad Illumination:** Adapt the keypad lighting to suit any environment by customising the brightness or colour based on the time of day.

For a comprehensive list of features, please refer to our product matrix on pages 38 – 41.

Flexible Configuration & Streamlined Management

- **Versatile Hub and Satellite Configuration:** For properties with multiple entry points or where different heights are needed for various vehicles, SOLO+ offers a versatile Hub and Satellite configuration.

(See page 32 for more information).

- **Effortless Remote Access and Programming:** Enables installers to program with ease via the Commtel CONFIG App. Provide end-users with convenient control using the Commtel CONTROL App

(See page 44 for more information).

Product Specifications

- **Dimensions:** H 216 x W 99 x D 35 mm
- **Faceplates:** All faceplates are stainless steel with an option for powder-coated anthracite grey (RAL 7016).
- **Surface Back Box Options:**
 - Moulded aluminium, powder-coated anthracite grey (RAL 7016).
 - 316 Marine grade stainless steel
- **Flush Back Boxes:** Flush back boxes are 316 Marine grade stainless steel.

SOLO+



Faceplate Finish Options

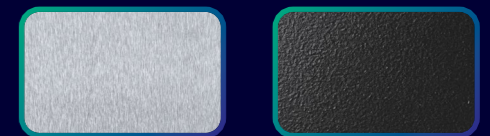

STAINLESS STEEL ANTHRACITE

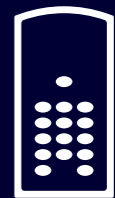

Click the icon to learn more about the SOLO+

DUO+



Faceplate Finish



STAINLESS STEEL



Click the icon to learn more about the DUO+

The DUO+ intercom provides a sleek and compact solution for efficient communication in divided properties or office spaces.

Offering a choice of two call buttons and an integrated keypad as standard, the DUO+ is a cost-effective alternative for applications requiring separate communication at a shared entrance.

Advanced Secure Entry

The DUO+ intercom, like the SOLO+, offers secure and flexible access control

- **Versatile Entry Authorisation:** Authorise entry for specific individuals, such as postal workers or tradespeople, using the built-in keypad and dial-to-open functionality.
- **Precise Timed Access Control:** Manage access effectively and prevent unauthorised entry with the built-in time clock, enabling time restrictions for specific users.

Flexible Configuration

- **Hub and Satellite Configuration:** For sites with multiple entry points or where different mounting heights are required for various vehicles, DUO+ systems offer a versatile Hub and Satellite configuration.

See page 32 for more information.

Product Specifications

- **Dimensions:** H 216 x W 99 x D 35 mm
- **Faceplates:** All faceplates are 316 Marine grade stainless steel.
- **Surface Back Box Options:**
 - Moulded aluminium, powder-coated anthracite grey (RAL 7016).
 - 316 Marine grade stainless steel
- **Flush Back Boxes:** Flush back boxes are 316 Marine grade stainless steel.



Commtel CONTROL App

Allows residents to operate their entry equipment at the push of a button.



Commtel CONFIG App

Simplify setup and management: remotely program all Commtel intercoms with the CONFIG app.

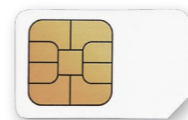

Choose the right SIM.

Discover the Commtel SIM tariff options, detailed on page 36.

The TRIO+ intercom, much like the DUO+, provides a sleek and compact solution for efficient communication in divided properties or office spaces with the benefit of an extra call button.

With three call buttons and an integrated keypad as standard, the TRIO+ continues to be a cost-effective alternative where separate communication at a shared entrance is required.

Advanced Secure Entry

The TRIO+ intercom offers secure and flexible access control

- **Versatile Entry Authorisation:** Authorise entry for specific individuals, such as postal workers or tradespeople, using the built-in keypad and dial-to-open functionality.
- **Precise Timed Access Control:** Manage access effectively and prevent unauthorised entry with the built-in time clock, enabling time restrictions for specific users.

Flexible Configuration

- **Hub and Satellite Configuration:** For sites with multiple entry points or where different mounting heights are required for various vehicles, TRIO+ systems offer a versatile Hub and Satellite configuration.

See page 32 for more information.

Product Specifications

- **Dimensions:** H 216 x W 99 x D 35 mm
- **Faceplates:** All faceplates are 316 Marine grade stainless steel.
- **Surface Back Box Options:**
 - Moulded aluminium, powder-coated anthracite grey (RAL 7016).
 - 316 Marine grade stainless steel
- **Flush Back Boxes:** Flush back boxes are 316 Marine grade stainless steel.

TRIO+



Faceplate Finish



STAINLESS STEEL

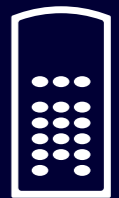

Click the icon to learn more about the TRIO+

JUNIOR

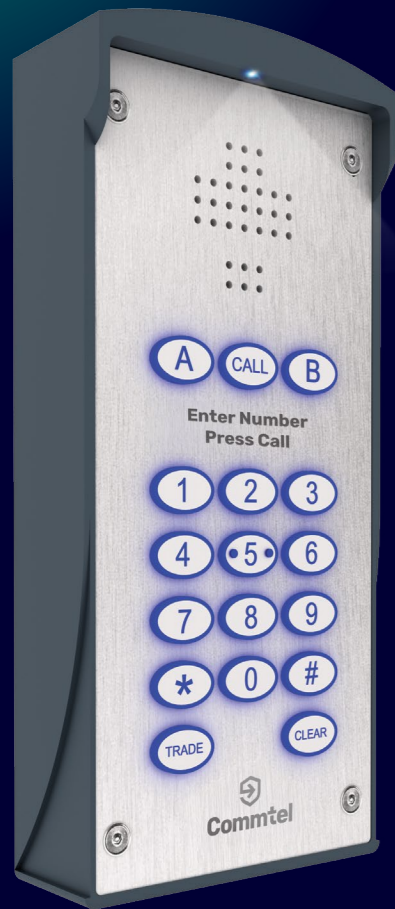

Faceplate Finish Options

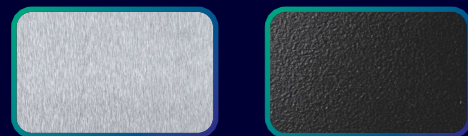

STAINLESS STEEL ANTHRACITE



Click the icon to learn more about the JUNIOR

The JUNIOR intercom is a digital multi-user system designed to serve up to 99 dwellings, providing a practical and convenient solution for visitor management.

This intercom facilitates easy access for both visitors and residents. Visitors can effortlessly contact individual properties by entering the door number followed by 'call', while residents and authorised personnel benefit from secure entry via PIN code.

Like all Commtel products, the JUNIOR is engineered with a range of valuable features to provide residents with convenience, security, and peace of mind.

For a comprehensive list of features, please refer to our product matrix on pages 38 – 41.

Advanced Secure Entry

The JUNIOR intercom offers enhanced and flexible access management.

- **Dial-to-Open Functionality:** Enable authorised entry for specific individuals, such as postal workers or tradespeople, by authorising their mobile number.
- **Timed Access Restriction:** Bolster security by implementing time restrictions for specific users, managed via the built-in time clock.

Flexible Configuration

- **Hub and Satellite Configuration:** For sites with multiple entry points or where varying mounting heights are required for different vehicle types, JUNIOR systems support a versatile Hub and Satellite configuration.

Further details are available on page 32.

Product Specifications

- **Dimensions:** H 216 x W 99 x D 35 mm
- **Faceplates:** All faceplates are stainless steel with an option for powder-coated anthracite grey (RAL 7016).
- **Surface Back Box Options:**
 - Moulded aluminium, powder-coated anthracite grey (RAL 7016).
 - 316 Marine grade stainless steel
- **Flush Back Boxes:** Flush back boxes are 316 Marine grade stainless steel.

Our VARIO intercoms are designed for versatility, adapting to a wide range of applications, from schools, hospitals, and universities to gated communities and individual residential properties.

This systems offer a suite of valuable features, including SMS event alerts, time-restricted access, and downloadable activity logs, providing enhanced security, peace of mind, and streamlined visitor management.

For a comprehensive list of features, please refer to our product matrix on pages 38 – 41.

Configuration options

- Up to 10 individual call buttons.
- Configurations with up to 6 buttons alongside a keypad or access control reader.
- Customisation options with engraving or vinyl labels.

Advanced Secure Entry

VARIO intercoms provide robust and flexible access management.

- **Dial-to-Open Functionality:** Authorise entry for specific individuals, such as postal workers or tradespeople, by authorising their mobile number.
- **Timed Access Restriction:** Enhance security by implementing time restrictions for specific users with our built-in time clock.
- **Access Control Integration:** VARIO systems offer integration with a variety of proximity and Bluetooth readers for expanded access control options.

Flexible Configuration

- **Hub and Satellite Configuration:** For sites with multiple entry points or where different mounting heights are required for various vehicles, VARIO systems offer a versatile Hub and Satellite configuration.

See page 32 for more information.

Product Specifications

- **Dimensions:** H 286 x W 126 x D 40 mm
- **Faceplates:** All faceplates are stainless steel.
- **Surface Back Box:** Moulded aluminium, powder-coated anthracite grey (RAL 7016).
- **Flush Options:** Flush options are available in stainless steel. Please contact our sales team for pricing and dimensions.

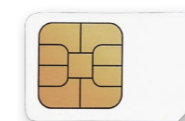

Choose the right SIM.

Discover the Commtel SIM tariff options, detailed on page 36.

VARIO+

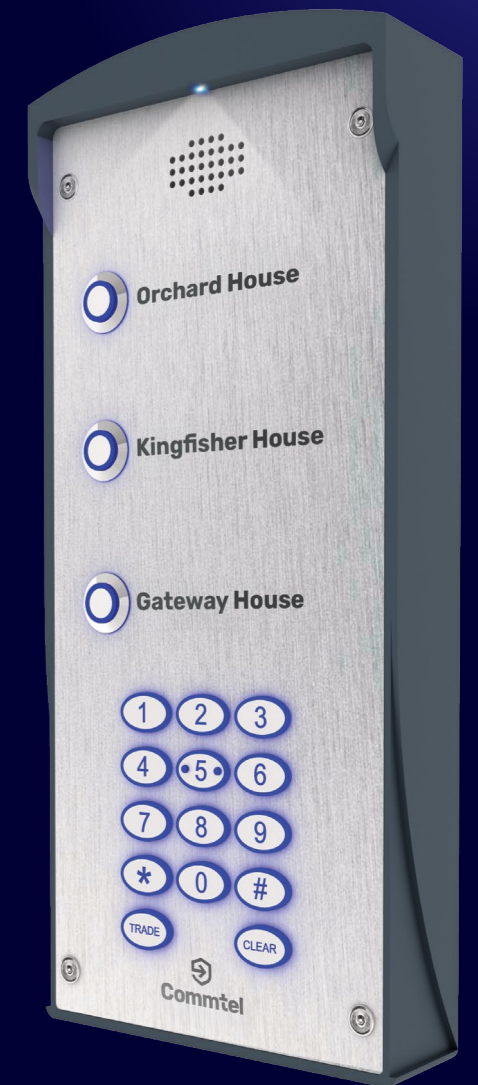

Faceplate Finish



STAINLESS STEEL

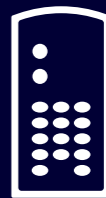

Click the icon to learn more about the VARIO+

MILLENNIUM



Faceplate Finish Options

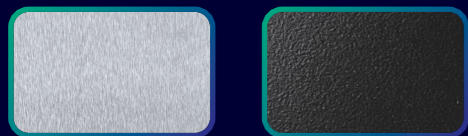

STAINLESS STEEL ANTHRACITE



Click the icon to learn more about the MILLENNIUM

Our MILLENNIUM intercom is a high-capacity solution designed to serve up to 1000 dwellings.

Featuring a user-friendly scrolling OLED directory, the Millennium offers simple and convenient visitor entry, making it an excellent choice for apartment blocks, industrial estates, and large office environments.

Advanced Secure Entry

The MILLENNIUM intercom provides comprehensive and flexible access management.

- **Versatile Entry Authorisation:** Authorise entry for specific individuals using the built-in keypad and dial-to-open functionality.
- **Timed Access Restriction:** Enhance security and control access by implementing time restrictions for specific users with our built-in time clock.
- **Expanded Integration Options:** We offer the integration of cut-outs for proximity and Bluetooth readers, as well as a range of other integration capabilities. (See page 42 for more information).

Flexible Configuration

- **Hub and Satellite Configuration:** For sites with multiple entry points or where different mounting heights are required for various vehicles, MILLENNIUM systems offer a versatile Hub and Satellite configuration.

Further details can be found on page 32.

Product Specifications

- **Dimensions:** H 286 x W 126 x D 35 mm.
- **Faceplates:** All faceplates are stainless steel, with an option for powder-coated anthracite grey (RAL 7016).
- **Surface Back Boxes:** Surface back boxes are moulded aluminium, powder-coated anthracite grey (RAL 7016).
- **Flush Options:** Flush options are available in stainless steel. Contact our sales team for pricing and dimensions.



Commtel CONTROL App

Allows residents to operate their entry equipment at the push of a button.

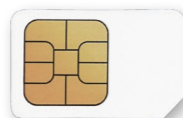

Choose the right SIM.

Discover the Commtel SIM tariff options, detailed on page 36.

The VISION system delivers a powerful combination of voice communication, access control, and video feeds through separate communication pathways.

This unique design ensures both critical access reliability and secure video functionality.

The separation of voice and video calls enhances communication dependability, reducing the possibility of missed visitors, particularly in areas where internet access may be inconsistent for reliable video streaming.

Residents can effortlessly receive video calls via the Commtel VISION app, designed for quick and easy setup and available for download on both iOS and Android devices.

The Vision App is available on both the Android App store and the Apple IOS App store.

For further comprehensive information or to enquire about the VISION, please visit our website or contact our sales team on +44(0)1306 710120 and choose option 2 or alternatively email: sales@commtel.io.

Product Specifications

- **Dimensions:** H 286 x W 126 x D 35 mm.
- **Faceplates:** All faceplates are stainless steel.
- **Surface Back Boxes:** Surface back boxes are moulded aluminium, powder-coated anthracite grey (RAL 7016).
- **Flush Options:** Flush options are available in stainless steel. Contact our sales team for pricing and dimensions.



Commtel CONFIG App

Simplify setup and management: remotely program all Commtel intercoms with the CONFIG app.



Commtel VISION App

Allows residents to view the video feed when receiving a call from one of our Vision panels.

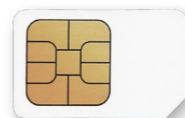

Choose the right SIM.

Discover the Commtel SIM tariff options, detailed on page 36.

VISION



Faceplate Finish



STAINLESS STEEL



Click the icon to learn more about the VISION

SENIOR



Faceplate Finish



STAINLESS STEEL



Click the icon to learn more about the SENIOR

Our SENIOR intercom provides a robust and feature-rich alternative to the MILLENNIUM system.

Featuring a scrolling OLED directory and SMS Event Alerts, the Senior offers enhanced visitor management alongside security and peace of mind for residents.

For a comprehensive list of features, please refer to our product matrix on pages 38 – 41.

Advanced Secure Entry

The SENIOR intercom offers advanced and flexible access management.

- **Versatile Entry Authorisation:** Authorise entry for specific individuals using the built-in keypad and dial-to-open functionality.
- **Timed Access Restriction:** Enhance security and control access by implementing time restrictions for specific users with our built-in time clock.
- **Expanded Integration Options:** We offer the integration of cut-outs for proximity and Bluetooth readers, as well as a range of other integration capabilities.

See page 42 for more information.

Flexible Configuration

- **Hub and Satellite Configuration:** For sites with multiple entry points or where different mounting heights are required for various vehicles, SENIOR systems offer a versatile Hub and Satellite configuration.

Further details can be found on page 32.

Product Specifications

- **Dimensions:** H 286 x W 126 x D 35 mm.
- **Faceplates:** All faceplates are stainless steel, with an option for powder-coated anthracite grey (RAL 7016).
- **Surface Back Boxes:** Surface back boxes are moulded aluminium, powder-coated anthracite grey (RAL 7016).
- **Flush Options:** Flush options are available in stainless steel. Contact our sales team for pricing and dimensions.

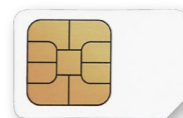

Choose the right SIM.

Discover the Commtel SIM tariff options, detailed on page 36.



Reliable solutions, unwavering support, lasting partnerships.

At Commtel, we believe an entry solution is about more than just technology.

It's about building strong relationships and providing the support you need, every step of the way. That's why we're committed to delivering reliable solutions and working alongside our customers to ensure their success.

Ready to discuss your next project? Contact our sales team for expert advice and tailored solutions.

Call +44(0)1306 710120 - (Option 2) or email sales@commtel.io

HY-CAN HUB

Hubs & Satellites

Commtel's Hubs & Satellites provide a flexible and cost-effective system architecture designed to manage multiple access points from a single location.

In this configuration, Satellites are the intercom units connected to a central Hub. The use of a Hub allows for significant cost savings on network connections, as only a single SIM card or landline/PBX connection is required per Hub.

Hubs enhance security by enabling the core system hardware to be located within a secure area.

Commtel's Hubs and Satellites can be mixed and matched with different Commtel intercom units, making them suitable for a wide range of applications where centralised control of multiple entrances is required, such as sites with multiple buildings, varying access heights for different vehicle types (e.g., cars and lorries), or numerous entry points spread across a large area.

For a comprehensive list of features, please refer to our product matrix on pages 38 – 41.

Key Features

- **Enhanced Security:** Hubs can be located on the secure side of the premises, enhancing overall system security.
- **Cost Efficiency:** Reduce running costs with the need for only a single SIM card or landline/PBX connection per Hub.
- **Flexible Programming:** Enjoy the flexibility to program all Satellites identically or configure them with individual programming parameters to suit specific needs.

Configuration Options

The optimal setup will vary depending on the specific location and usage requirements. Options include:

- Choice of either a 4G or analogue Hub.
- Support for up to 4 Satellites without a display.

OR

- Support for up to 3 Satellites with a display.

*Cabling is required between the Hub and Satellites.

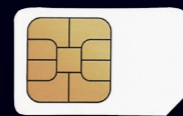

Choose the right SIM.

Discover the Commtel SIM tariff options, detailed on page 36.

Up to a maximum of three Millennium **OR** three Senior units.

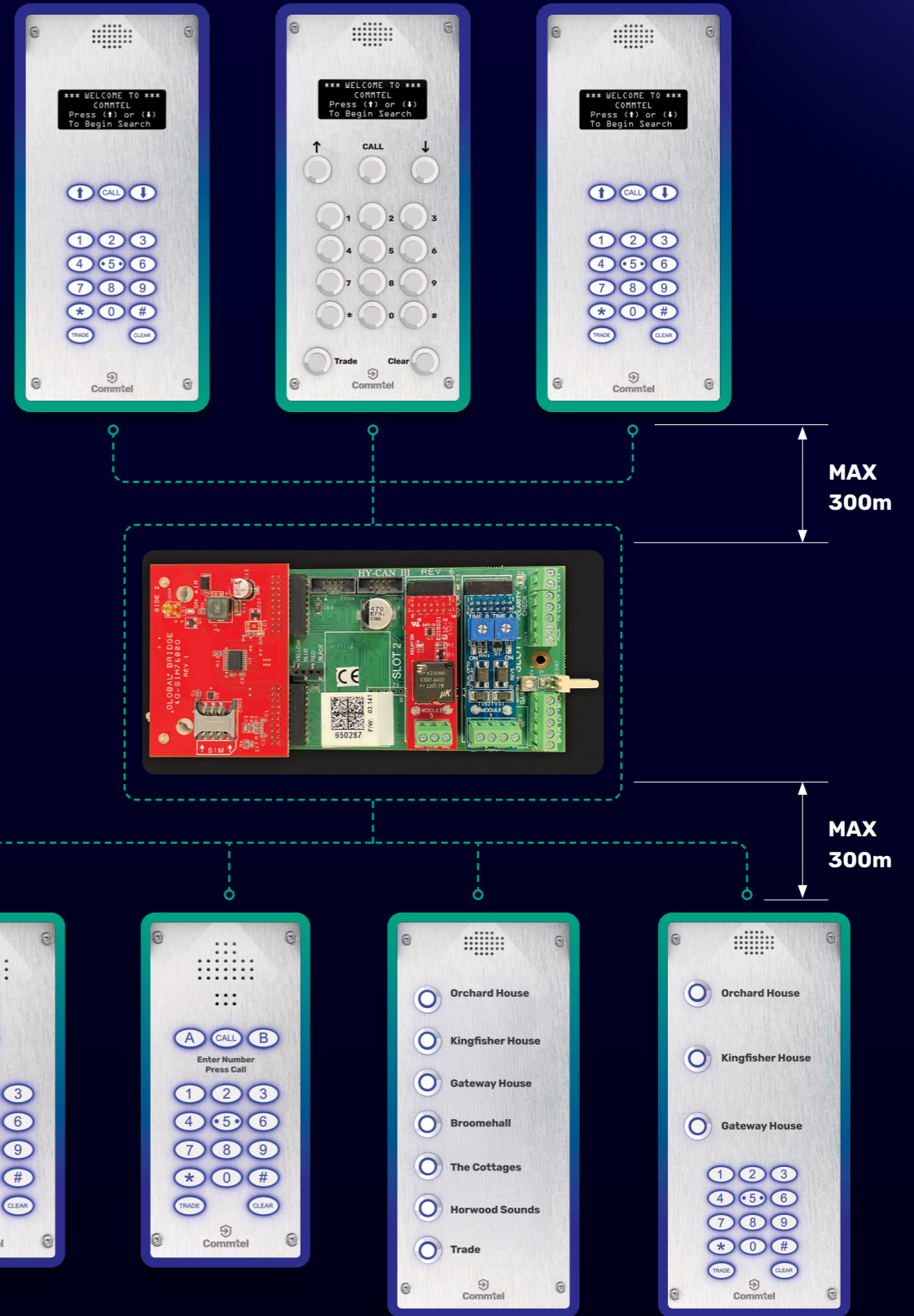

OR up to four SOLO / SOLO+ / DUO+ / TRIO+ / JUNIOR / VARIO.

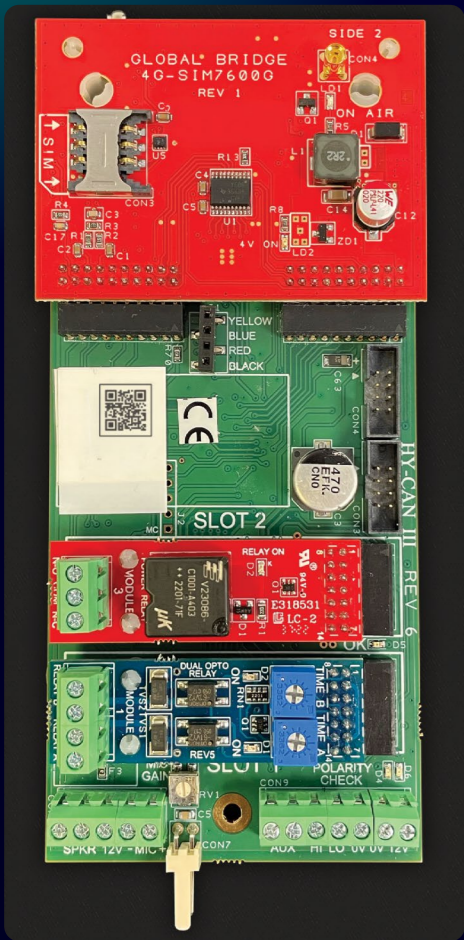





Commtel CONFIG App

Simplify setup and management: remotely program all Commtel intercoms with the CONFIG app.

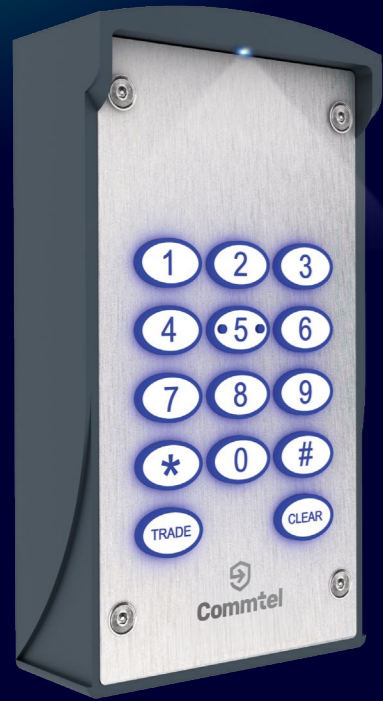
TELPAD II

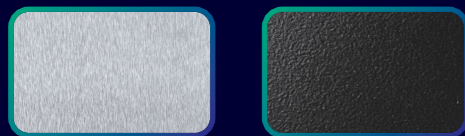

Faceplate Finish Options



STAINLESS STEEL ANTHRACITE



Click the icon to learn more about the TELPAD II

The Telpad II enhances access control when paired with any Commtel intercom or Hub, providing secure keypad entry in situations where audio communication at the entrance is not required.

A key advantage of the Telpad II over standalone keypads lies in its remote programming capability. Eliminate the need for manual entry code management and simplify access control administration using our Commtel CONFIG app

(See page 44 for more information).

The Telpad II also leverages the intelligent, built-in features of the connected system, such as the time clock and activity logs. Furthermore, on-board SMS notifications can be programmed to alert you of any activity.

For a comprehensive list of features, please refer to our product matrix on pages 38 - 41.

Key Features

- **Remote Programming:** Program the Telpad II remotely via a connected Commtel intercom or Hub.
- **Timed PIN Codes:** Implement time-restricted access control using timed entry codes.
- **Event Alerts:** Receive notifications of access events with programmable event alerts.
- **Activity Log:** Review a log of events and enhance security with the integrated activity log.

Versatile Application

The Telpad II can be utilised as an entry or exit keypad for various applications, including:

- Doors
- Gates
- Turnstiles
- Barriers
- Bollards

Product Specifications

- **Dimensions:** H 166 x W 89 x D 35 mm
- **Faceplates:** All faceplates are stainless steel with an option for powder-coated anthracite grey (RAL 7016).
- **Surface Back Boxes:** Surface back boxes are moulded aluminium, powder-coated anthracite grey (RAL 7016).

The Commtel Command Unit is our advanced 4G switch, the next generation of remote access technology evolving from our original GSM Dialler.

Programmed and controlled with ease via the CU Companion app, the Command Unit provides simple, hassle-free, and reliable remote entry and control of any powered entrance using the 4G network.

For a comprehensive list of features, please refer to our product matrix on pages 38 - 41.

Key Features

- **Connectivity:** 1 x Auxiliary Input, 1 x Relay Output
- **Enhanced Access Control:** Authorise access for up to 1300 users, enabling door or gate operation with a simple call - a modern and cost-effective alternative to traditional access control systems.
- **Integrated Time Management:** The built-in time clock facilitates timed entry, providing precise control over access permissions.
- **Activity Logging:** Review a log of events and enhance security with the integrated activity log.

Streamlined Management

- Effortless Remote Access and Programming:
- Installers can program and configure the unit with ease via the Commtel CONFIG App.
- End-users benefit from convenient control through the CU COMPANION App.

(See page 44 for more information).



Commtel CONFIG App

Simplify setup and management: remotely program all Commtel intercoms with the CONFIG app.



Commtel CU COMPANION App

Allows users to programme and control the Command Unit system using the CU COMPANION app.

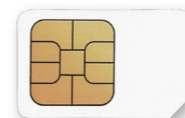

Choose the right SIM.

Discover the Commtel SIM tariff options, detailed on page 36.

COMMAND UNIT

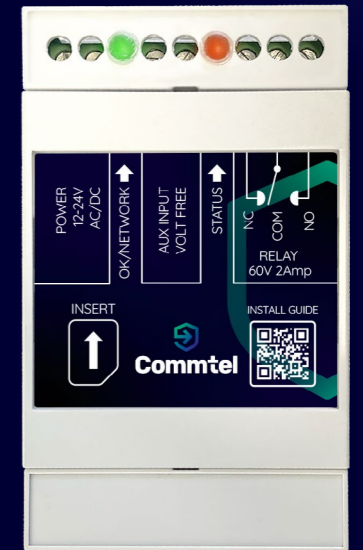

Click the icon to learn more about the COMMAND UNIT

SIM CARDS



Ensuring a reliable connection starts with selecting the right SIM.

With so many networks and tariffs to choose from, finding one that truly suits your Commtel intercom can be challenging. Most SIM cards are built for use in mobile phones, not for static systems like intercoms, which have very different demands.

That's why it's important to choose a SIM that's purpose-built for consistent performance.

Key Considerations

Intercoms operate differently to mobile phones. They're often installed in areas where signal strength varies and exposed to conditions a phone would never face. More importantly, they rely on a stable connection to deliver critical communication, every time.

Selecting a SIM and tariff designed for machine use ensures your Commtel intercom performs as it should: reliably, securely, and without interruption.

Choosing the Right SIM

Network Coverage:

Selecting a SIM card on the best network in the area is key. We recommend using a signal analyser to get an accurate signal reading at the intercom's antenna location.

Marketing messages:

Standard mobile SIMs often receive SMS or MMS marketing messages, which can interfere with intercom performance. Ask your network provider to disable these messages before use.

Our SIM Tariffs

At Commtel, we believe in empowering our customers with control over their billing.

That's why we offer both flexible pay-monthly tariffs and streamlined pay-annually plans, designed to accommodate diverse financial preferences and operational requirements.

Voice & SMS SIMs

Voice & SMS SIMs are suited to audio intercoms, remote relay control, and installations using voice calling, SMS commands, or event alerts. Essential tariffs are typically suited to lower-use sites such as single dwellings, gates, barriers, or occasional access systems.

Our unlimited tariffs are better suited to multi-resident or higher-traffic installations where regular call activity is expected.

Essential Tariff (Pay-Monthly)

- Networks: O2 or Vodafone
- **£4.95** monthly fee + VAT*
- 100 calls & texts to UK numbers**
- 100MB data included (for remote programming)***
- 30-day rolling contract.

Unlimited Tariff (Pay-Monthly)

- Networks: O2, Vodafone & EE
- **£16.50** monthly fee + VAT*
- Unlimited calls & texts to UK numbers**
- 100MB data (O2 & Vodafone)
250MB data (EE)***
- 30-day rolling contract.

Unlimited Annual Tariff (Pay-Annually)

- Networks: O2, Vodafone
- **£198** annual fee + VAT*
- Unlimited calls & texts to UK numbers**
- Monthly data allowance of 100MB (O2 & Vodafone)***
- Annual contract (upfront payment required).

Data SIMs

Our Data SIMs are intended for IP and video-based systems using app connectivity or video transmission where stable data communication is required.

Multi-network connectivity helps maintain stable communication in areas where signal availability may vary.

Data Tariff (Pay-Monthly)

- Multi-Networks: Covering O2, Vodafone & EE
- **£7.50** monthly fee + VAT*
- 1GB data included***
- 30-day rolling contract.

Data Tariff (Pay-Annually)

- Multi-Networks: Covering O2, Vodafone & EE
- **£90** annual fee + VAT*
- 1GB data included***

* All prices quoted are subject to change.

** Texts used for SMS text alerts and programming confirmation responses.

*** A small amount of data is used for programming when done remotely using our software.



Tariff & Network Guidance

For assistance in selecting the most suitable SIM card for your intercom system, please click the icon, or contact our sales team: call +44(0)1306 710120 - (Option 2) email sales@commtel.io, or visit: commtel.io/sim-cards/

PRODUCT MATRIX



NX1

NX250

SOLO

SOLO+

DUO+

TRIO+

JUNIOR

PRODUCT CODES:
NX1

PRODUCT CODES:
NX250

PRODUCT CODES:
4G: ML4SO
SATELLITE: SMLSO

PRODUCT CODES:
4G: ML4SO+
SATELLITE: SMLSO+

PRODUCT CODES:
4G: ML2+
SATELLITE: SML2+

PRODUCT CODES:
4G: ML3+
SATELLITE: SML3+

PRODUCT CODES:
4G: ML4TJ
SATELLITE: SMLTJ

Connectivity	4G - IP	4G - IP
Number of Users / Number of Call Buttons	1	250
User Capacity	500	1000
Call Forwarding	6	6
Access Codes	1500	15000
Temporary Codes	Y	Y
Authorised Dial-To-Open	1500 *	15000 *
Relay Outputs Supplied	3	3
Auxiliary Inputs	2	2
Activity Log	Y	Y
Push Notifications	Y	Y
Internal Time Clock with Time Profiles	Y	Y
Programmable Backlit OLED Display	-	Y
Timed Trade Button	Y	Y
SMS Alerts	-	-
Option for Anthracite Faceplate	-	-
Option for Flush Mounting (Stainless Steel Only)	-	-
Programmable via App	Y	Y

4G	4G	4G	4G	4G
1	1	2	3	99
-	-	-	-	-
7	7	7	7	7
-	400	400	400	400
-	Y	Y	Y	Y
1300	1300	1300	1300	1300
3	3	3	3	3
2	2	2	2	2
Y	Y	Y	Y	Y
-	-	-	-	-
Y	Y	Y	Y	Y
-	Y	Y	Y	Y
-	Y	Y	Y	Y
Y	Y	Y	Y	Y

* SIP Subscription required, find out more in the product user guide, downloadable on our website

Our supportive sales team is ready to assist you with solving your secure entry needs. Call **+44(0)1306 710120** - (Option 2) or email sales@commtel.io

PRODUCT MATRIX



VARIO/VARIO+

PRODUCT CODES:
4G: 4BD(X) / 4BDC(X)
SAT: SBD(X) / SBDC(X)



MILLENNIUM

PRODUCT CODES:
4G: 4BDM
SATELLITE: SBDTM



VISION

PRODUCT CODES:
4G: 6BDM



SENIOR

PRODUCT CODES:
4G: 4BDTS
SATELLITE: SBDTS



HUB

PRODUCT CODES:
4G: 4TH
LANDLINE: LTH



TELPAD II

PRODUCT CODES:
TTP2



COMMAND UNIT

PRODUCT CODES:
4TGCU

Connectivity	4G	4G	4G	4G	4G / Landline	-	4G
Number of Users / Number of Call Buttons	2-10 / 1-6	1000	1000	1000	-	-	-
User Capacity	-	-	-	-	-	-	-
Call Forwarding	7	7	7	7	-	-	-
Access Codes	NA / 400	400	400	400	-	400 *	-
Temporary Codes	Y	Y	Y	Y	-	Y *	-
Authorised Dial-To-Open	1300	1300	1300	1300	-	1300 **	1300
Relay Outputs Supplied	3	3	3	3	3	-	1
Auxiliary Inputs	2	2	2	2	1	-	1
Activity Log **	Y	Y	Y	Y	Y	As per connected unit	Y
Push Notifications	-	-	-	-	-	-	-
Internal Time Clock with Time Profiles	Y	Y	Y	Y	Y	As per connected unit	Y
Programmable Backlit OLED Display	-	Y	Y	Y	-	-	-
Timed Trade Button	N / Y	Y	Y	Y	-	Y	-
SMS Alerts	Y	Y	Y	Y	Y	Y *	Y
Option for Anthracite Faceplate	-	Y	-	-	-	Y	-
Option for Flush Mounting (Stainless Steel Only)	-	-	-	-	-	-	-
Programmable via App	Y	Y	Y	Y	Y	As per connected unit	Y

* Shared with connected Commtel unit.

** This is available by a request from our Technical Support Team

Our supportive sales team is ready to assist you with solving your secure entry needs. Call **+44(0)1306 710120** - (Option 2) or email sales@commtel.io

CUSTOM SOLUTIONS

Commtel understands that every project presents unique challenges. That's why we offer fully customisable intercom solutions.

Going beyond standard offerings, we collaborate with you to create tailored systems that seamlessly integrate into your project design and deliver optimal functionality.

We can accommodate site-specific dimensions to ensure perfect integration, and offer variable button configurations with up to 100 buttons for large-scale or complex applications. Tailored button layouts optimise the user experience, while personalised aesthetics are achievable through engraving and a variety of finishes.

To enhance accessibility, we provide the option for expanded functionality with cut-outs to house proximity readers, Bluetooth readers, biometrics, and cameras.

Our supportive sales team is ready to assist you with your custom intercom needs.

Call +44(0)1306 710120 - (Option 2).



YOUR VISION. Our Expertise.

At Commtel, we understand that off-the-shelf solutions don't always meet the unique demands of every project. That's why we offer extensive customisation options, allowing you to create secure entry systems that perfectly align with your vision.

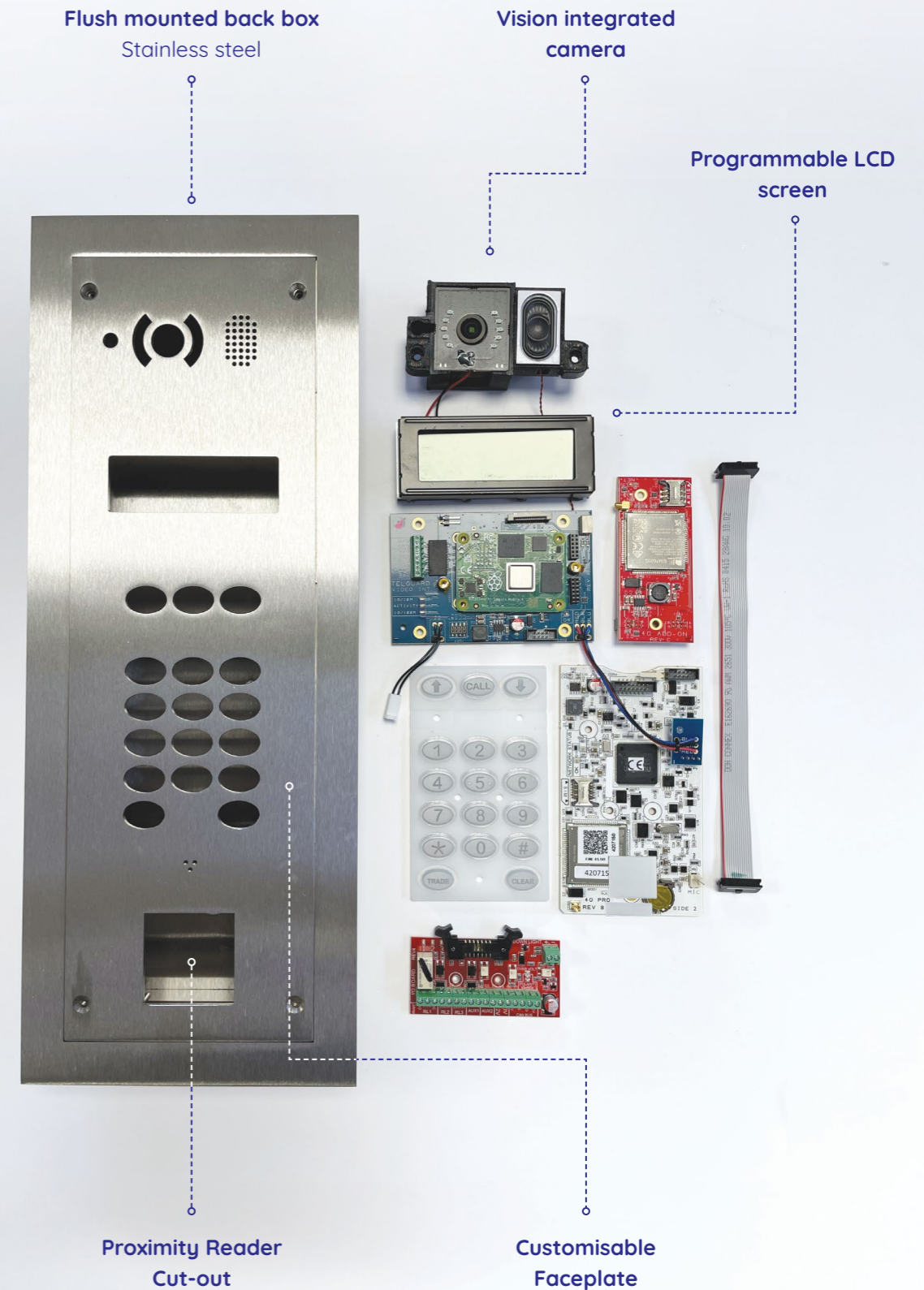

We know your time is valuable. That's why we have created a suite of intuitive, user-friendly apps designed to give you complete control from the palm of your hand.

Our apps are a direct extension of our commitment to seamless, user-centric solutions. They simplify every stage of the process, from a quick and easy setup to ongoing management and seamless operation.

With tools that make installation faster and features that give end-users effortless control, we're providing the support you need, when you need it most.

We don't just build products; we build solutions that work for you.



You can download the Commtel apps for free, from either the Android or iOS app stores.

INSTALLER PROGRAMMING APP

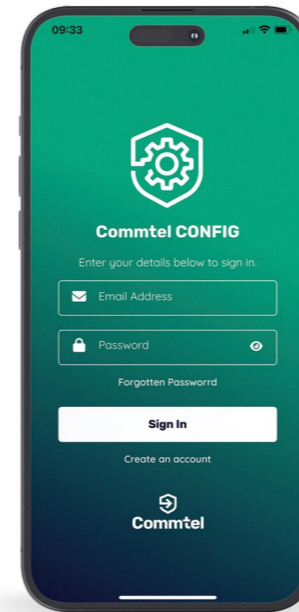

Commtel CONFIG App

The Commtel CONFIG app makes it quick and easy to program and manage your Commtel intercoms or your Command Unit.

For user instructions within the app, you can click on the help icon in the top right of the screen.

[Download the Commtel CONFIG User Guide](#)

END-USER APPS



Commtel CU COMPANION

Lets users control and configure their Command Unit using simple SMS commands.

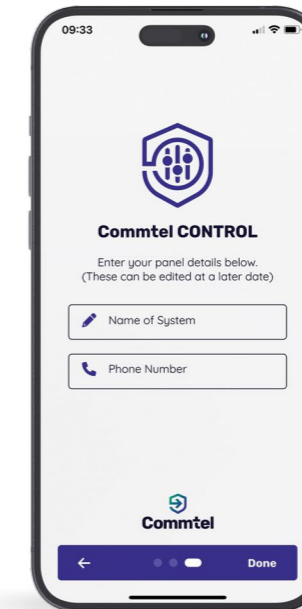

Commtel CONTROL

Control your Commtel systems using simple SMS commands.

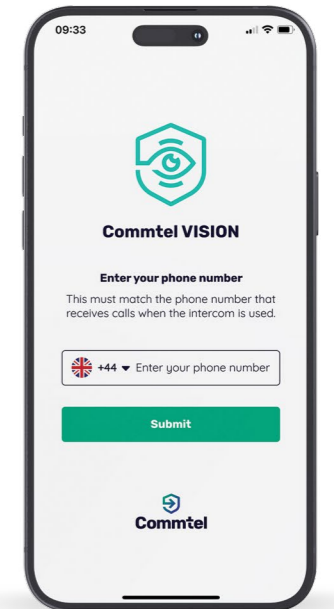

Commtel VISION

Allows users to view the video feed when receiving a call from the Vision intercom.

Commtel Ltd.

ORCHARD HOUSE, 39 GATWICK ROAD
CRAWLEY, WEST SUSSEX RH10 9RB

 +44 (0) 1306 710120

 sales@commtel.io

 www.commtel.io



Cert No. 12535
ISO 27001



Raising Standards
Advancing Safety

